

Servel
by Dometic

INSTALLATION AND OPERATING INSTRUCTIONS

REFRIGERATOR FOR KEROSENE OPERATION.

Model RK 400

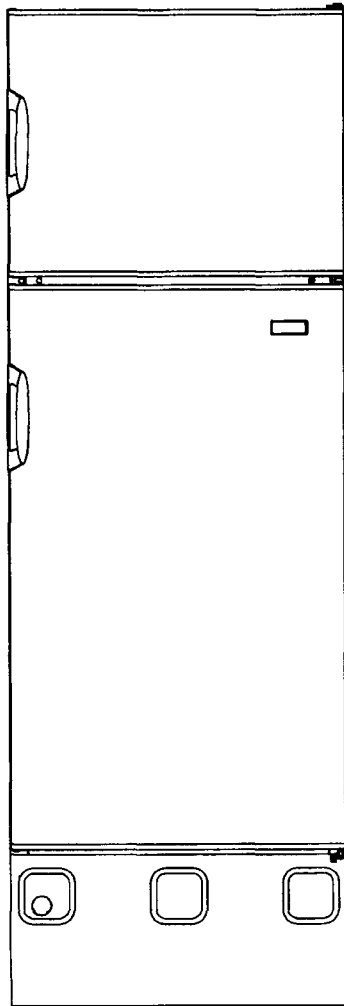

**RECORD THIS INFORMATION FOR FUTURE
REFERENCE BEFORE INSTALLING THE UNIT:**

Model No. Serial No.
Product No.
Date Purchased
Place of Purchase

Corporate Office
2320 Industrial Parkway Elkhart, IN 46515

USA
Service Office
The Dometic Corporation
509 South Poplar Street
LaGrange, IN 46761
Phone: 219-463-4858

For Service Center Assistance
Call: 800-544-4881

CANADA
Dometic Distribution Inc.
866 Langs Drive
Cambridge, Ontario
N3H 2N7 Canada
Phone: 51 g-653-4390

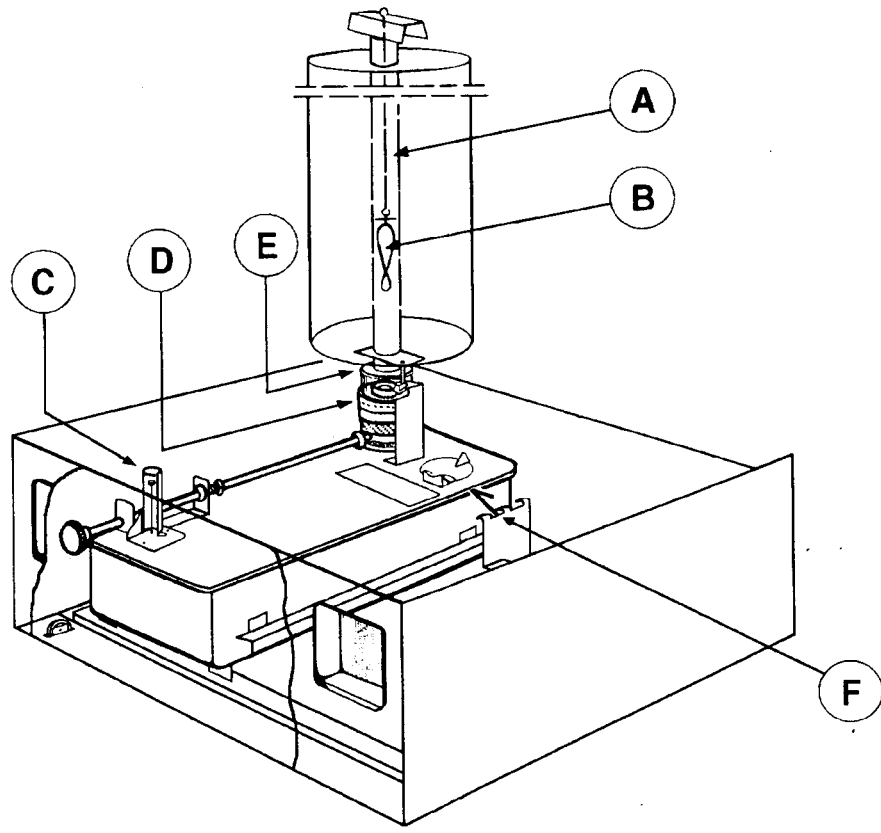

A. Flue tube
B. Flue baffle

C. Fuel gauge
D. Burner

E. Seal ring
F. Lever arm

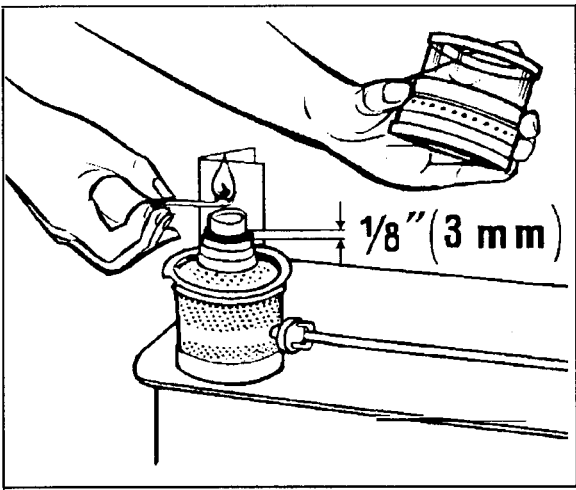

1

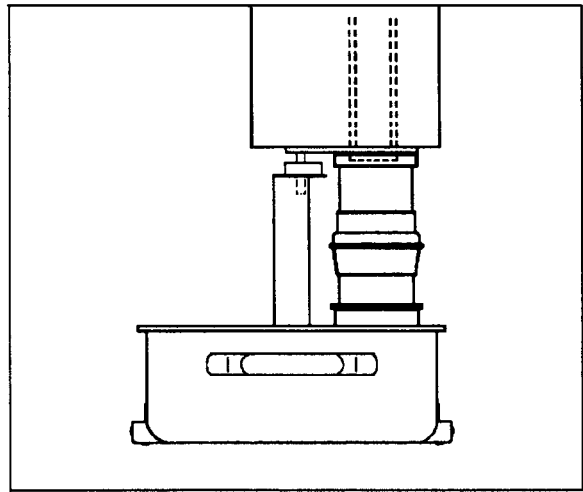

2

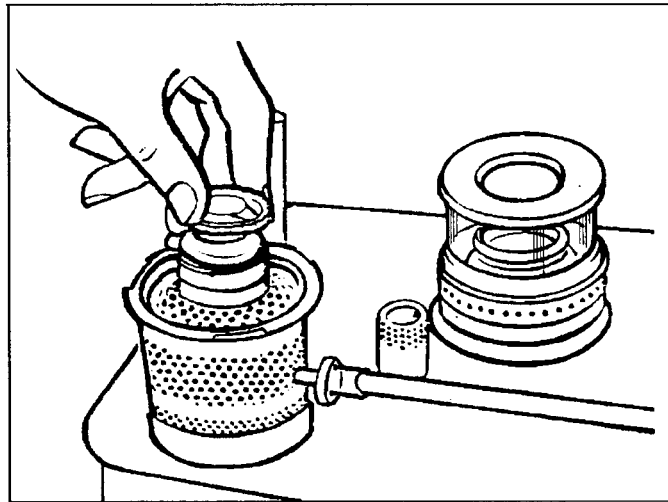

3

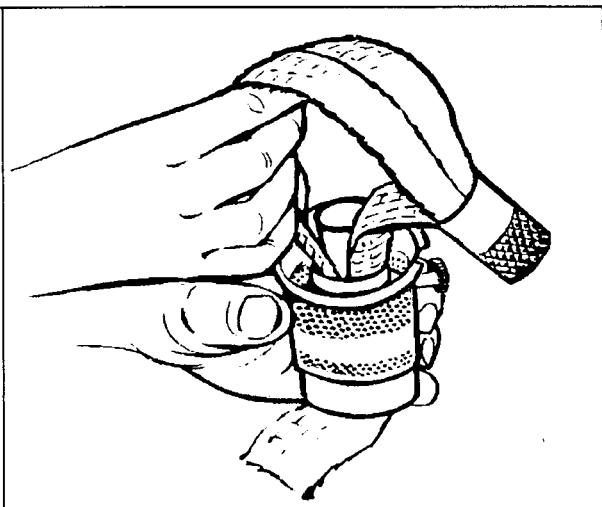

4

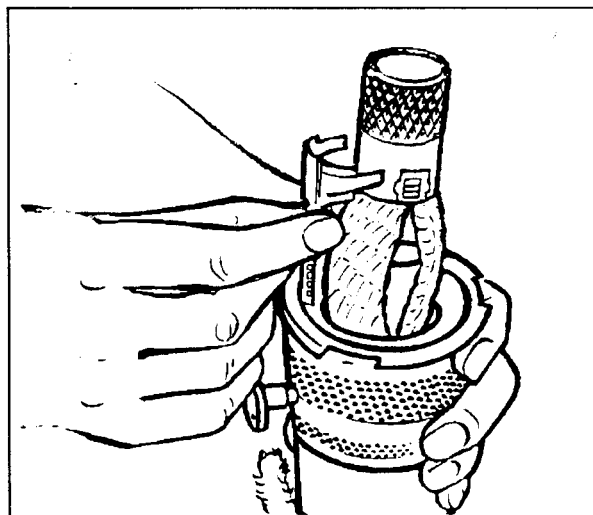

5

INSTRUCTIONS FOR USE

Installation

The cabinet must be installed on a firm floor and must be in a horizontal position. Use a water level and check both ways in the freezer compartment.

Avoid locating the refrigerator in a room subject to high temperatures or strong draughts.

See that a space of at least 16 inches (400 mm) is left free above the top of the cabinet to allow an unrestricted circulation of air, which is essential for the efficient operation of the refrigerator. The ventilation opening at the top of the cabinet must not be covered in any way.

The refrigerator should not be placed in a small pantry or similar location.

The flue baffle must be positioned as shown on the illustration.

Filling the Tank

Always use the kerosene funnel when filling the tank, and fill until the gauge pointer approaches the red mark. Clean off any kerosene on the top of the tank. If kerosene overflows, the tank should be removed from the refrigerator and wiped clean.

Do not let the tank run dry while the refrigerator is in use because refrigeration will be interrupted and a portion of the wick will be burned off, reducing the life of the wick.

Always use best quality burning kerosene (Paraffin) and see that it is kept clean, dry and unadulterated. Under no circumstances must vaporizing kerosene, petrol or spirit of any kind be used.

Lighting the Burner

Remember that the kerosene lamp is an essential part of the refrigerator and that care taken to maintain it in good condition is well repaid.

Before lighting a new wick for the first time, allow the wick to become soaked with kerosene for at least two hours.

Important

When lighting the burner, remove the gallery, lamp glass and seal ring as one unit after turning the gallery anti-clockwise to unlock. (FIG. 1) Do not attempt to light the burner by turning up the wick as high as it will go, leaving the gallery in place, as this will damage the wick and result in unsatisfactory refrigeration.

Adjust the wick turner so that the wick height is about 1/8" (3 mm) above the top of the outer wick tube.

(FIG. 1).

Light the wick. Allow the flame to travel round the wick, and replace the gallery complete with lamp glass and seal ring. Turn the gallery clockwise until locked securely in position. Should the flame be extinguished, relight, following the above procedure.

Push the tank into the tank holder underneath the cabinet and at the rear of the refrigerator. Slide the tank carefully forwards against the guide pin. Carefully lift the tank by means of the lever arm and check that the guide pin enter the hole in the bracket on the left side of the burner. (FIG. 2).

Make sure that the sealing ring on the top of the lamp glass seals against the bottom of the flue tube, it should not be any air gap between the flue tube and the sealing ring. Lock the lever arm in the position where the sealing ring seals against the flue tube.

The burner should burn with a blue flame; a partly or wholly yellow flame indicates an air gap and must be adjusted.

When the burner is in position under the flue tube, adjust the wick to produce a medium-high blue flame. Wait 30 minutes to allow the burner to warm up before making any further wick adjustments. To obtain better cooling, turn the wick up which raises the light-blue flame.

To make the refrigeration less cold, turn the wick down to give a blue flame of reduced height. To maintain steady cabinet temperatures the refrigerator should operate continuously day and night.

NOTE: Never operate the burner with a flame having yellow tips or streaks on or in the bright blue lower portion, or with a wholly yellow flame. Such conditions will result in rapid carbonizing of the wick, smell, and possible damage to the cooling unit.

Do not force wick turner if it will not turn readily, as this may be an indication that the burner needs cleaning or that the wick should be replaced.

Cleaning Wick and Burner

While the flame is burning, carbon forms on the top of the wick, on the flange of the outer wick tube and on the surface of the flame spreader. For the best refrigeration results and to prolong the life of the wick, this carbon must be cleaned off every two or three days for the first two weeks and at least once a month thereafter, provided a good grade of kerosene is used. When poor grade kerosene is used, the burner should be cleaned at least once a week.

To clean the wick and the burner, loosen the lever arm and pull out the tank, remove the seal ring, lamp glass and gallery by turning it anti-clockwise and lift off. Take out the flame spreader. Insert the wick cleaner, (supplied with the burner) in the burner tube and adjust the wick by pressing the cleaner gently against the wick surface. Turn the wick cleaner in a clock-wise direction, gently cleaning and reshaping the burning surface (FIG. 3).

Be careful not to fray the wick.

The top surface of the properly cleaned wick should be free from carbon and frayed fabric threads. It should slope upwards to its inner top edge, which should be fairly even.

Blow off all loose carbon from the wick and burner, and remove any dirt or carbon which has fallen into the burner base.

Reassemble the burner.

When cleaning the burner, take out the burner from the tank and inspect the tails of the wick. If they are dirty, unsuitable kerosene has been used and the tank must be cleaned. Empty the tank and put the dirty kerosene aside for other uses. Rinse the tank twice with clean kerosene and refill with filtered kerosene.

Replacing the Wick

Remove burner from tank. Remove outer wick tube (see Burner Parts) by turning it anti-clockwise to unlock, and lifting it off the burner.

Turn the wick up as far as possible. Pull the wick and the wick carrier out from the top of the burner. Disengage the wick from the wick carrier.

A new wick should be free from moisture (water).

Before inserting the new wick, make sure that the flame spreader is in position in the burner tube.

New wicks have adhesive papers at the tail ends to afford ease of replacement, and these should first be straightened out. Put one of the papers through the opening around the wick tube, and pull in the paper until the fabric end of the wick is through the opening. Repeat the procedure with the other end of the wick in the opposite opening around the wick tube (FIG. 4). When both wick tails are through the respective openings, pull the wick through the burner until about 1" (25 mm) of the tails protrudes below the bottom of the burner.

Be careful not to fray the top of the wick during replacement.

Install the wick carrier on the wick, ensuring that the rack of the wick carrier is on the same side as the wick turner (FIG. 5). Ease the wick and wick carrier downwards by pulling gently on the bottom ends of the wick, and when the rack of the wick carrier enters the annular opening, guide it against the cog wheel on the wick turner.

Depress the wick carrier rack over the cog wheel of the wick turner and move the wick down as far as it will go. Be sure that the inside reinforcement tape of the wick slips over the burner tube. If the wick gets stuck in the burner, do not force the wick turner as this may damage the wick carrier.

Replace the outer wick tube on the burner, pressing it down and turning it clockwise to lock in position. Check that the wick can be turned up and down readily.

To prolong the life of the wick, it should be cleaned every two or three days for the first two weeks and once a month thereafter, provided a good grade of kerosene is used. When poor grade kerosene is used, the burner and wick should be cleaned at least once a week.

Only Aladdin wicks can be used in this burner.

Cleaning the Flue System

Cleaning of the flue at least once every year is, however, recommended. Poor grade kerosene may cause the burner to smoke, and as soot will then collect in the flue it should be cleaned immediately. To clean the flue remove the tank and burner, lift off the flue cap complete with wire and flue baffle, and place a sheet of paper underneath the flue tube to catch the soot. Clean the flue with the brush supplied with the refrigerator and, after cleaning, **ensure that the flue cap and baffle are refitted in position.**

NOTE: The refrigerator will not operate properly if the flue baffle is not in place.

Defrosting

Remove all food from the refrigerator, extinguish the flame and leave the door and frozen storage compartment door open. The frost will melt rapidly and run down into a receptacle at the rear of the refrigerator where it evaporates. Defrost water in the freezer compartment should be mopped up with a cloth.

It is advisable to clean the refrigerator in conjunction with defrosting. Use lukewarm water and a non-perfumed detergent. Never use scouring powder, steel wool and the like.

Before starting the refrigerator again, dry out the frozen storage compartment and refrigeration space. Wash the ice-trays and fill them with fresh water.

Turning off

If the refrigerator is to remain out of use, extinguish the burner flame. Empty the cabinet, defrost it and clean it thoroughly. Leave the door ajar.

Lighting

The refrigerator is provided with a battery power interior light.

The battery box is at the rear of the refrigerator.

Four batteries, type LR20 1,5 volts are to be used.

Fault Tracing Chart

Cause and Remedy

Refrigerator not cold enough

1. Air circulation restricted round the unit.
See that a space of at least 16 inches (400 mm) is left free above the top of the cabinet. (See "Installation").
2. Refrigerator not level.
Level cabinet so that the sides and the front are vertical. (Use a water level).
3. Yellow flame
 - a) Incorrectly lit.
Relight correctly. (See FIG. 1).
 - b) Improper chimney seal.
(See FIG. 2).
 - c) Wick requires cleaning.
Clean wick and burner. (See FIG. 4).
 - d) Needs new wick.
Replace the wick. (See FIG. 5 and 6).
 - e) Inferior grade of kerosene-paraffin.
Drain and refill the tank. Fit a new wick.
 - f) Flue requires cleaning.
(See "Cleaning the flue system").
4. Flame too low or too high.
5. Evaporator heavily frosted.
Turn out the flame to defrost.
6. Refrigerator overloaded.
Spread food stuffs on shelves to permit free air circulation in the cabinet.
7. Flickering flame (water in kerosene-paraffin).
Keep storage drum or container in dry place with lid on to prevent condensed water to enter the container.

Refrigerator too cold

1. Yellow flame.
Burner incorrectly lit. Relight correctly. (See FIG. 1).
2. Flame too high.
Turn down the flame.

Points to remember

- Keep the refrigerator level.
- Defrost weekly or fortnightly.
- Keep the burner clean.
- Never use force to turn up the wick mover;
- Do not overload the refrigerator so that the air cannot circulate freely inside the cabinet.
- Use only good grade of kerosene-paraffin.
- Do not let the fuel tank run dry.
- Inspect the flame regularly.
- **Always have a blue flame.**

Burner Parts (Aladdin 23E).

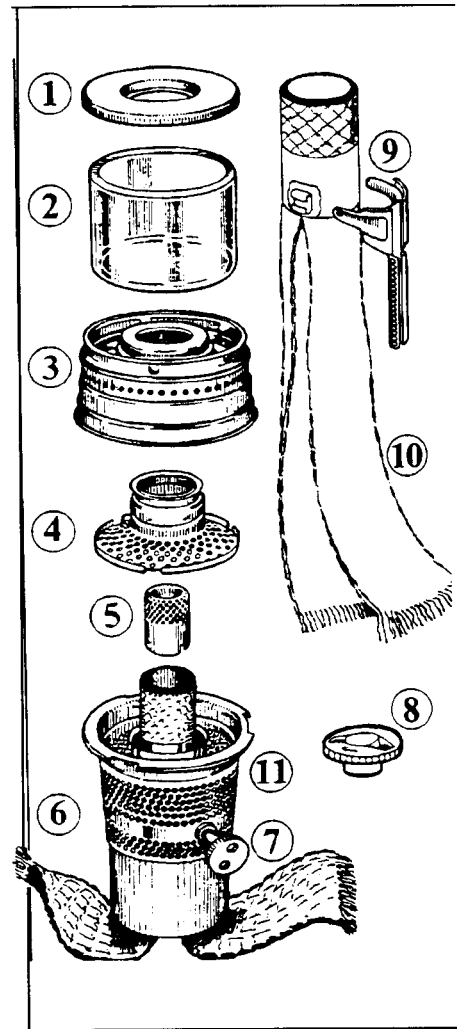

1. Seal ring 2. Lamp glass 3. Gallery 4. Outer wick tube
5. Flame spreader 6. Burner base 7. Wick turner 8. Wick cleaner 9. Wick carrier 10. Wick 11. Burner complete (without lamp glass and seal ring).