

KOBE® Premium

So Quiet...

You Won't Believe It's On!

NEW

Now with
Upgraded features
Available in June 2013



CH9136SQB-1 (36" shown)
Wall Mount



CH9130SQB-1 (30" shown)

CH-191 SQB-1 Series Multi Style

Model / Size	CH9130SQB-1 / 30" CH9136SQB-1 / 36" CH9142SQB-1 / 42" CH9148SQB-1 / 48"
Appearance	
Stainless Steel	✓
Seamless	✓
Performance	
CFM	300 to 760
Sone / Decibel	1.0 to 4.5 / 40dB to 62dB
Features	
QuietMode™	1.0 / 40dB
ECO Mode	10 Minutes on QuietMode™ Every Hour to Promote a Cleaner Kitchen Air Quality
LED Lights	3-Level Lighting 3W x 2 (30" , 36") 3W x 3 (42" , 48")
Speed	6-Speed
Control	Electronic Buttons with LED Display
Blower Type	Twin Vertical Turbine Impeller
Exhaust	Top - 6" Round, Top - 3-1/4" x 10" Rectangular Rear - 3-1/4" x 10" Rectangular
Consumption/ Ampere	30" & 36" - 232W / 2.21A 42" & 48" - 235W / 2.23A
Power Supply	120V 60Hz
Filter	Baffle
Optional Accessories	
Duct Cover	CH1120DC-1
Stainless Steel Back Splash	SSP30 (30" x 32") / SSP36 (36" x 32")

Under Cabinet

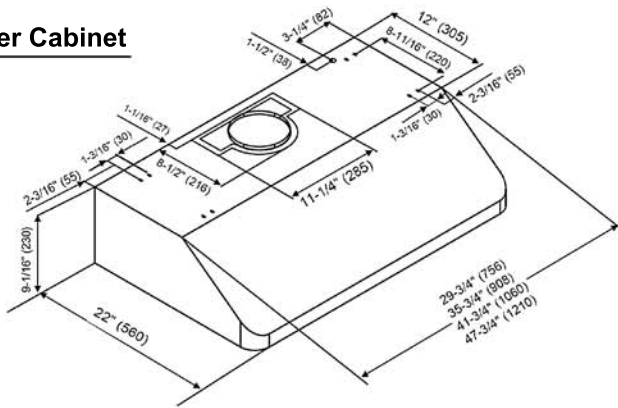

Wall Mount

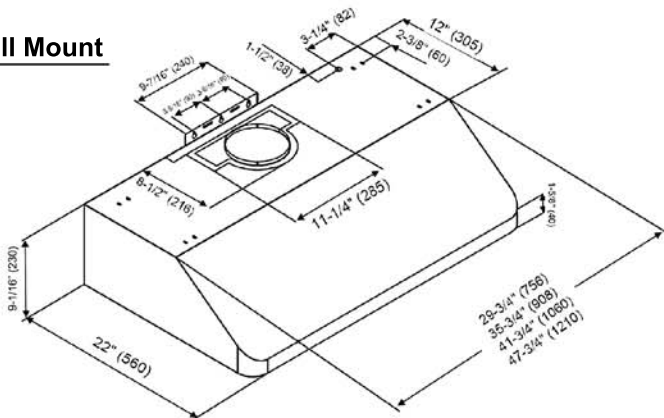

Wall Mount (with Duct Cover)

Duct Cover (Required)

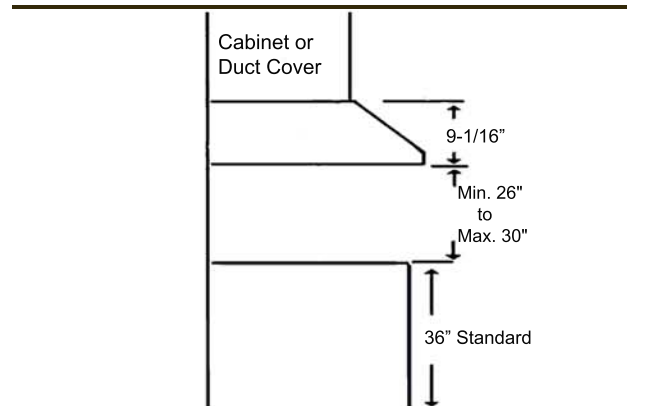
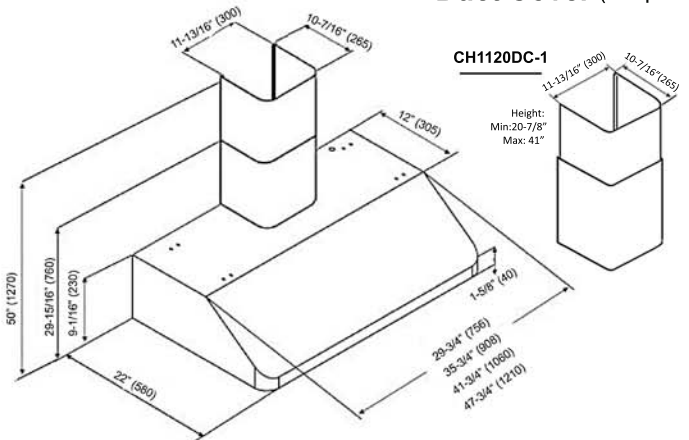

Information subject to change without notice.

Measurement in inches (mm). Inches are converted from millimeter and are estimated.

* Building code may vary.

www.KOBERangeHoods.com

VER. 130501